

Wall Mount CO2 Monitor Operating Instructions

Model: ZGw08PR-R

2010.10.20

Product Overview

Thank you for selecting ZGw08PR-R CO2 wall mount monitor. This product was developed to detect the presence of CO2 in the ambient air and to help people to take care of the Indoor Air Quality. By using the CO2 monitor as the indicator, it can easily measure the current CO2 concentration together with the ventilation rate, ambient temperature and relative humidity. A comfortable indoor environment comes from a healthy CO2 concentration. The ZGw08PR-R can be widely used in a variety of places, such as the office building, green house, school, exhibition facilities, and shopping malls/stores.

The ZGw08PR-R is easy to use and has many features:

- NDIR (Non-Dispersive-Infrared) technology used to measure CO2 concentration
- Three different LED display show the current Indoor Air Quality situation
- Reliable Sensor provides long-term calibration stability
- Visual and audible alarm function can be adjusted by the user

Caring for Your Product

To ensure to receive maximum benefit from using this product, please observe the follow guidelines.

1. Cleaning—Disconnect the power before cleaning. Use a damp cloth; do not use liquid cleaning agents, such as benzene, thinner or aerosols.
2. Repair—Do not attempt to repair the product or modify the circuitry by yourself. Please contact the local dealer or a qualified repairman if the product needs servicing.
3. Calibration— Please observe the calibration operation to make sure the accuracy for the device when necessary.
4. Air circulation—The vents allow the air circulation liquid for measurement of the CO2 concentration and the ventilation should not be blocked.

Safety Notes

Warning: Your safety is very important to us. To ensure to use the product correctly and safely, we would like to draw your attention to read the warning labels and the User Manual before using the product. These are important safety information and should be observed at all times.

1. Please handle the device lightly; do not subject the product to impact or shock.
2. Do not immerse the product in water.
3. Do not touch the exposed electronic circuitry of the device under any circumstances. Keep the circuit closed during installation, as there is the danger of electric shock.
4. Please use only the included power adaptor. Improper power adaptors or power sources can cause serious damage to the product, or result in injury or death to the user.
5. Do not keep the product under hot and/or extremely moist environment. Keep the product away from any heat source or near water.
6. Please confirm whether the screw is surely fixed to the wall. The screw must not touch the PCB board while installing it. There is a risk of giving the damage to a circuit or the damage which recovery does not attach to a device.
7. The RJ45 socket is only for factory calibration use, not for LAN, it was covered by plastic cover, the incorrect RJ 45 connection will have the risk of circuit damage or irreparable damage to devices.
8. Please pay attention to the connection indication of the terminal. The circuit of equipment will be destroyed if it attaches the mistaken operation and the mistaken contrary.
9. Please employ a CO2 monitor in the place where the handle of child does not reach to avoid danger and an Accident.

Operation Instruction

Front view

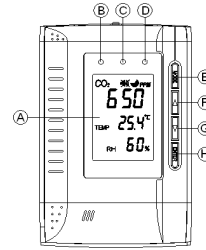

Back view

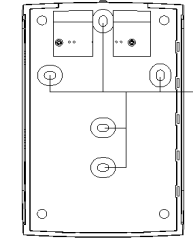

Side view

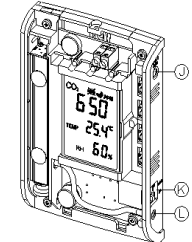

- | | | | |
|---------------------|--------------------------------|--|-------------------------------|
| A. Main LCD Display | B. Green LED Display (<800ppm) | C. Yellow LED Display (800-1200ppm) | D. Red LED Display (>1200ppm) |
| E. Mode Button | F. Up Button | G. Down Button | H. Enter Button |
| I. Screw Position | J. Power Inlet | K. RJ 45 Socket (For factory use only) | L. Gas Entry Hole |

LED display explanation

- | | |
|--|--|
| | : A favorable level |
| | : A healthy normal outdoor level |
| | : CO2 density - 800ppm~ |
| | : Sleepiness generally happens |
| | : When I feel unpleasantness and a smell, there is it |
| | : CO2 density 800ppm~1,200ppm |
| | : The healthy damage is expected for |
| | : The healthy damage is expected for a long time when I follow |
| | : CO2 density 1,200ppm or more |

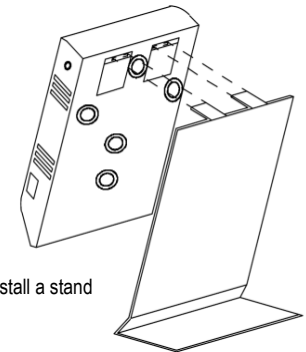

How to install a stand

(It is possible to use it as a desk-top type with the AC adaptor with a special stand and 6V plug AC adaptor and a special stand with

Dimension

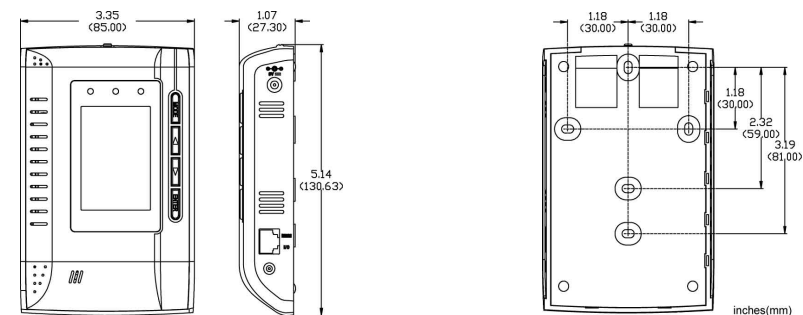

LCD Display Symbol

Symbol	Meaning	Description
CO ₂ PPM 650	CO2 Concentration PPM Parts Per Million	The current CO2 concentration in the household
TEMP 25.4°C	Temperature(Celsius)	The present temperature in the household
RH 60%	RH	The relative humidity
	Alarm	The beep Alarm Icon, the buzzer will sound when the red LED lights, the factory setting with alarm is buzzer off
WARM UP	Warm Up	The stability time to let the device to measure the accurate value (70 seconds)
MUTE	Mute	The beep alarm can be setting on/off under Mute Mode
ALTI	Altitude	Compensate the pressure changes with appropriate altitude of location when measure
ALARM 1	Alarm 1	The first alarm level 400ppm - 2,900ppm
ALARM 2	Alarm 2	The second alarm level 500ppm - 3,000ppm
CALI	Calibration	To calibrate the CO2 sensor when the accuracy deviates from the actual CO2 concentration
DATALOGGER	Data logger	Display the past CO2 of every 30 minutes ,RH and temperature records in the past 24 hours. 48 times display
MAX MIN	Max Min	Display the Max and Min CO2 reading record before being cleared or the device is powered off
CLr	Clear	To clear the Max and Min CO2 reading record
RcFS	Recover Factory Setting	To Recover Factory Setting to cancel the customizing Setting

Wiring Connection

- 1. Relay Norm Open
- 2. Relay Common
- 3. 9VDC GND
- 4. 9VDC+

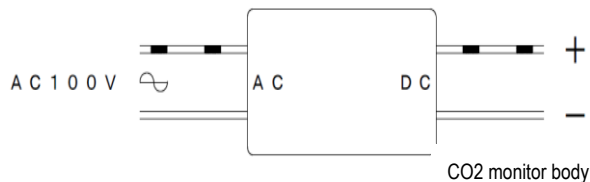

Installation Step

Before installation, please carefully take out all parts from the package.

Step 1: Release the screw from the device by screwdriver, and take the front cover off.

Step 2: Release the four screws from the back cover, take the CO2 board from the back cover.

Step 3: The AC/DC converter power line must tie from power supply BOX to 110VAC or 220VAC power line.

Note: Before connecting 10VAC/220VAC in order to avoid danger please turn off power.

Step 4: That assembles wiring box and back cover with a screw again.

Step 5: Assembles CO2 board and back cover with a screw again.

Step 6: Please connect the power line of an AC/DC converter with a power terminal. (Refer to the following figure)

Step 7: Please install the front cover in the liquid crystal display when the connection of the terminal block ends.

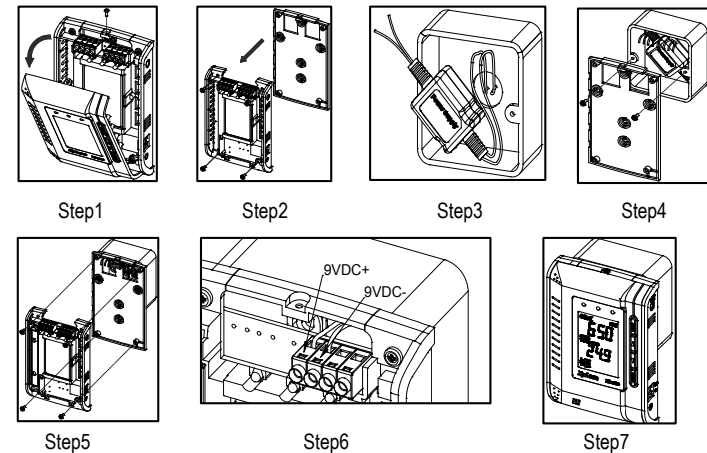

Customizing Settings

When the power has been connected, The ZGw08PR-R CO2 monitor will begin to work. In order to meet your personal requirements, it is advisable to set up the customizing parameters.

WarmUp: It lasts approximately 1min before WARM UP disappears; all MODE functions will not response during warm up.

■Each mode setting

When the MODE button is pushed, the display of ..set mode.. blinking is done in following the order.

MODE Button ⇒ MUTE ⇒ ALTI ⇒ ALARM 1 ⇒ ALARM 2 ⇒ CALI ⇒ DATALOGGER ⇒ MAX MIN ⇒ RcFS

Next decide a mode I push the ENTER button next, and to change setting of.

Furthermore, I push UP button · the DOWN button and change setting of it and I push the ENTER button last and am finished.

Temperature (°C) and RH:

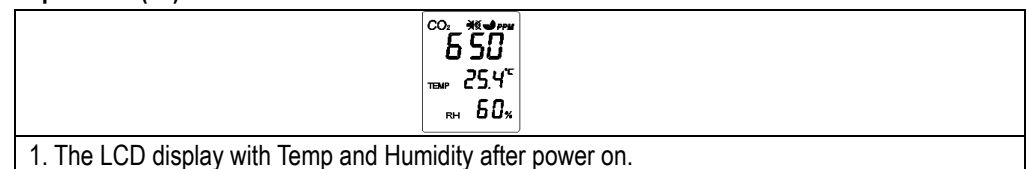

Note: Temp °C refers to Temperature in Celsius;

Using the MUTE function:

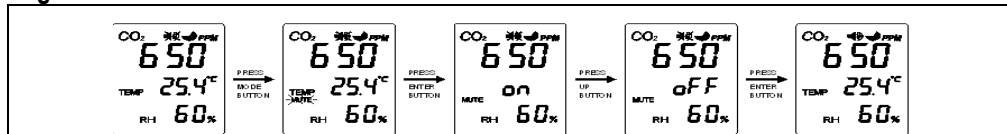

1. Press **F**MODE, the MUTE icon flashes simultaneously.
2. Press **H**ENTER, use **F**Up/**C**Down to select the on/off.
3. Press **H**ENTER again to save the data.

Note: The factory setting with alarm is buzzer off, user can set the alarm on/off according to MUTE function instruction.

Setting the ALTI mode:

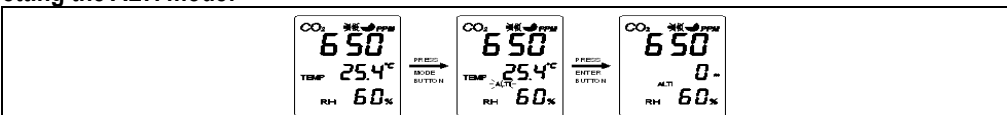

1. Press **F**MODE, the ALTI icon flashes.
2. Press **H**ENTER, ALTI show on the display And press the mode button to alter the m(meter)
3. Adjust altitude (step=100m) by **F**Up/**C**Down button.
4. Press **H**ENTER again to save the data.

Setting the ALARM 1 level:

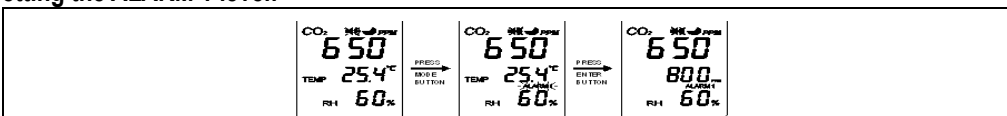

1. Press **F**MODE, the ALARM 1 icon flashes.
2. Press **H**ENTER. Using the **F**Up/**C**Down to set the parameter. the default alarm 1 is 800 ppm.
3. Press **H**ENTER again to save the data.

Note: 1) When the CO2 Alarm level is $\geq 1,000$ ppm, the interval is ± 100 ppm, when the CO2 Alarm level is $< 1,000$ ppm, the interval is ± 50 ppm.

2) Alarm 1 is possible to adjust between 400ppm - 2,900ppm

3) After setting with new alarm level parameter, the green LED will light when CO2 concentration below the alarm 1st level.

Setting the ALARM 2 level:

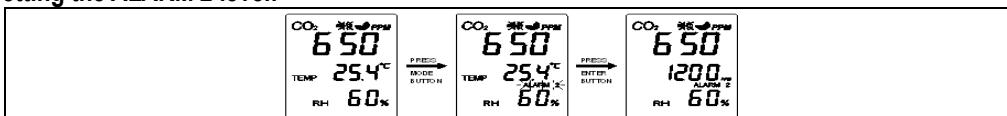

1. Press **F**MODE, the ALARM 2 icon flashes.
2. Press **H**ENTER. Using the **F**Up/**C**Down to set the parameter. the default alarm 2 is 1200 ppm
3. Press **H**ENTER again to save the data.

*Note: 1) When CO2 Alarm level is $\geq 1,000$ ppm, the interval is ± 100 ppm, when the CO2 Alarm level is $< 1,000$ ppm, the interval is ± 50 ppm.

2) Alarm 2 is "Alarm 1 +100 ppm" can be adjusted from between 500ppm - 3000ppm.

3) After setting with new alarm level parameter, the green LED will light when CO2 concentration below the alarm1 level. The red LED will light when CO2 concentration exceeds the alarm 2 level, the yellow LED will light when CO2 concentration is between the alarm1st level and the alarm 2nd level.

Using the CALI (calibration) Mode:

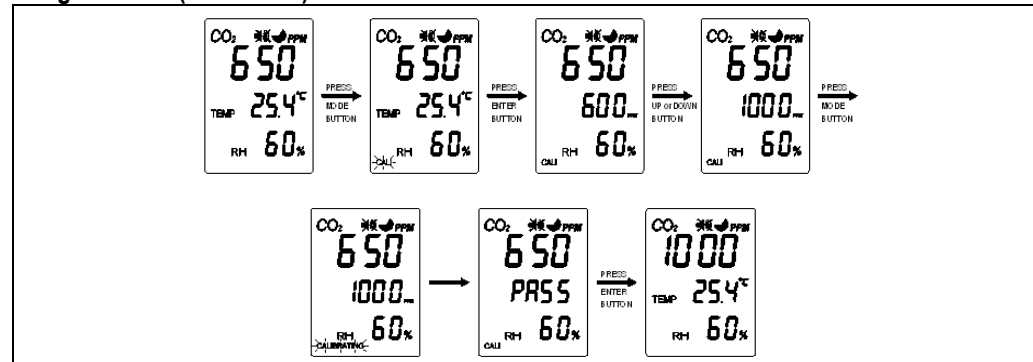

1. Press **F**MODE, The CALI flashes.
2. Press **H**ENTER, the CALI icon on the display. Adjust the lower display to the ambient CO2 reading by **F**Up/**C**Down button.
3. Press **F**MODE for more than 10sec, CALIBRATION flashes. Calibration will be done automatically after 3 minute and the LCD will display "Pass" or "Fail." If it shows "Fail," please try again.

Setting the Datalogger Mode:

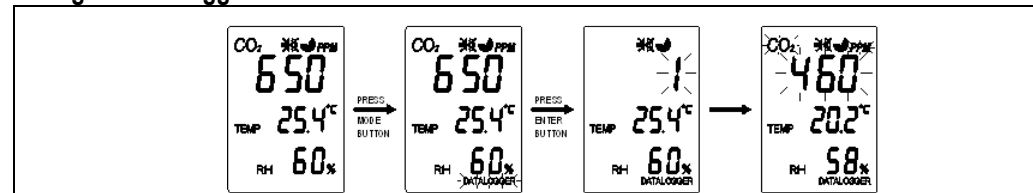

1. Press **F**MODE, DATALOGGER icon flashes.
2. Press **H**ENTER, the reading of CO2,RH and Temperature show on the LCD.
3. Press **F**Up/**C**Down to page up/down the reading. The numbers from 1 to 48 will display with CO2 reading alternatively. If the LCD display with number "1", it indicates the first datalogger with CO2,RH and temperature reading,. The datalogger function can record 48 sets reading.

Remark: With the Built-in Datalogger,ZGw08PR-R can provide the past CO2,RH and temperature reading within the past 24 hours. The log interval is 30 minutes per data. ZGw08PR-R is connected with power and used for the first time, If the working time is more than 30 minutes, ZGw08PR-R will have CO2,RH and temperature reading in datalogger, if the working time is less than 30 minutes, the LCD will display "NULL" while using the datalogger function.

Using the MAX MIN Mode:

	→		→		→		→	
1. Press MODE , the MAX MIN flashes simultaneously.								
2. Press ENTER , the reading of CO2, RH and Temperature show on the LCD alternatively.								
3. Press Up/Down and the "CLR" will flash on the LCD. Press Enter to CLEAR the MAX and MIN record.								

Note: With the Built-in MAX MIN mode, ZGw08PR-R can provide the Maximum and Minimum CO2, RH and temperature reading record after the device is powered on. If users press up/down to clear the MAX and MIN CO2 reading record, ZGw08PR-R will provide the new MAX and MIN CO2, RH and temperature reading from that time.

Using the "RcFS" Mode:

	→		→		→	
1. Press MODE , The RcFS flashes simultaneously.						
2. Press ENTER , the icon "no" shows on the LCD, Press the Up/Down to select the no/yes.						
3. After selecting, press ENTER to save the changes.						

Note: If the users set the data or calibrate the sensor wrongly. You can use the RcFS (Recover the factory Setting) to come back to factory setting data, the datalogger with 48 sets of CO2, RH and temperature will be cleared.

Specification

Method – NDIR Sample Method -Diffusion or flow through (50 ~200 ml/min)

Temperature specification:	
Temperature Range	Display 0°C to 50°C(32°F to 122°F)
Display Resolution	0.1°C(0.1°F)
Display Options	°C / °F
Accuracy	±1°C(±2°F) when the fan blows to the device directly, the accuracy of temperature is +/- 1.5 °C
Response Time	20-30 minutes (case must equalize with environment)
RH Specification:	
Measurement Range	20%-90% RH
Display Resolution	1%RH
Accuracy	±5%RH@23°C
Response Time	<5 min for 63% of step change

Operating Conditions:

Humidity Range	0 ~ 95% RH non-condensing
CO2 Specifications:	
Measurement Range	0~ 3,000 ppm display
Display Resolution	1ppm at 0~1,000ppm; 5ppm at 1,001~2,000ppm; 10ppm at 2,001~3,000ppm
Accuracy	0~2,000ppm, ± 70 ppm or ±5% of reading whichever is greater; over 2000ppm: +/-7%
Temperature Dependence	±0.2% of reading per °C or ±2 ppm per °C, whichever is greater, referenced to 25°C
Pressure Dependence	0.13% of reading per mm Hg (Corrected via user input for altitude)
Response Time	<2min for 90% of step change
Warm-Up Time	About 60 seconds at 22°C
Zone LED Display	Ref.No. : 082010 Green:<800ppm Yellow:800~1200ppm Red: >1200ppm
Power Supply	6VDC AC adapter
Storage Temperature	-20°C to +60°C(-4°F to 140°F)

Calibration

Note: Before calibrating, you need to obtain standard gas or semi-standard gas, there are 3 ways to get standard gas.

Method A: use CO2 in office/building

- Use two meters (One is the device for calibration. The other one is a calibrated (new) one.
- Use ambient room gas for calibration in office, waiting at least 10min, until the CO2 reading doesn't change (Notice: user must not breathe toward the ZGw08PR-R, CO2 from the user will affect the reading of ZGw08PR-R)
- Use the reading of the new device as the standard reading.
- Calibrate device by the Cali Mode instruction.

Method B: use CO2 outdoors

- Use ambient room gas for calibration outside. Wait at least 10min, until the CO2 reading stabilizes. (Notice: user must not breathe toward the ZGw08PR-R, CO2 from the user will affect the reading of ZGw08PR-R)
- Use 380~420ppm as the standard reading.
- Calibrate the device by the Cali Mode instruction.

Method C: use standard CO2 in the bottle

- Pump the standard CO2 gas(0~1000ppm, flux = 0.1~0.2 liter/min) into the ZGw08PR-R from the Gas Entry Hole, waiting about 2~3min.
- Calibrate the device by the Cali Mode instruction.

Ref.No. 082010



ZyAura
Monitoring the invisible

C.H.C.
C.H.C. SYSTEM CO.,LTD.

Carbon Offset Station
Plants